

## 5MHz, 3-Pole, Low-Pass Filter plus Video Line Driver for Consumer Video Applications

The MAX4390 operational amplifier configured in a 3-pole, low-pass Sallen-Key filter that provides a Butterworth response with a bandwidth of -3dB at 5.25MHz. This circuit can be used for video anti-aliasing and reconstruction filtering for composite (CVBS) or S-Video signals in standard definition digital TV (SDTV) applications. The circuit is designed to drive a 75-ohm termination, common in video applications, with an overall gain of 1.

The Sallen-Key realization of a 5.25MHz, 3-Pole Butterworth filter shown in Figure 1 has a gain of 2V/V and is capable of driving 75Ω back-terminated coax to an overall gain of 1. Used to reconstruct component-video (Y, Pb, Pr) and RGB signals, this filter has an insertion loss of >20db at 13.5MHz and >40db at 27MHz (Figure 2). Like the anti-aliasing filter before an ADC, this filter is used to remove the higher-frequency replicas of a signal following a DAC.

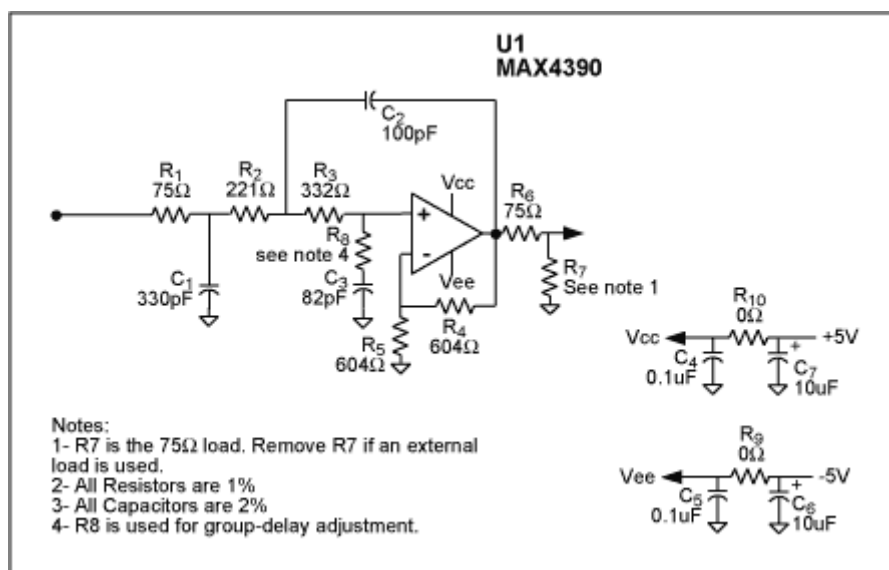

Figure 1. This 3-pole Butterworth video-reconstruction filter has adjustable group delay.

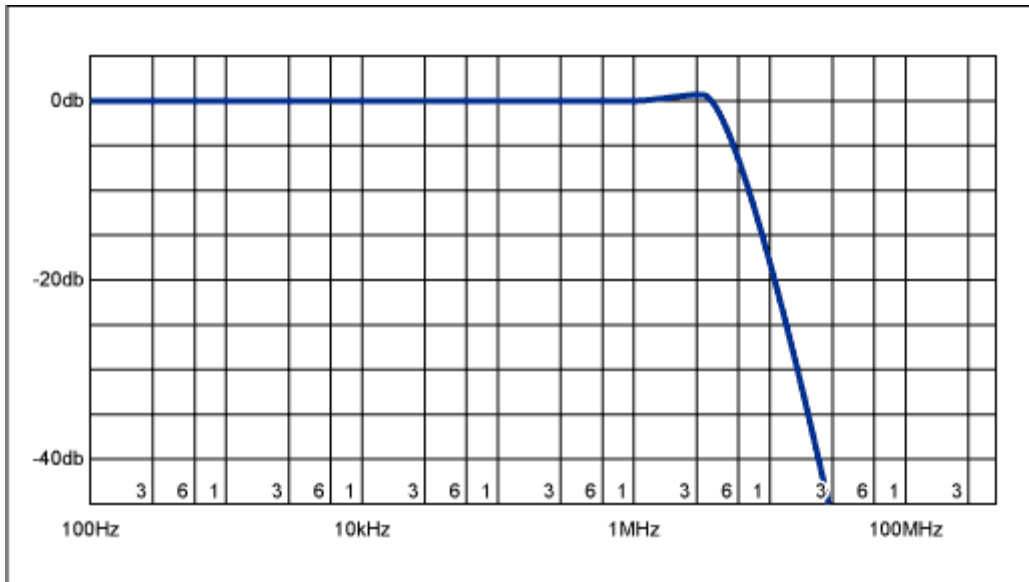

Figure 2. Typical filter response for circuit of Figure 1 with  $R3 + R8 = 332 \Omega$  .

To preserve quality in the video waveform, one should minimize group-delay variations in the filter and also any group-delay differential between filters. That capability requires a means for adjusting the filter's group delay without affecting its bandwidth. In Figure 1, the addition of R8 in series with C3 and R3 creates a lag-lead network. Keeping the sum of R3 and R8 constant and equal to the original R3 value preserves bandwidth by preserving the dominant-pole frequency. Increasing the R3 value, on the other hand, introduces a "lead" term that lowers group delay by reducing the rate of change in phase.

For  $R8 = 0\Omega$  and  $R3 = 332\Omega$  in the circuit shown, the average group-delay variation over the filter bandwidth is about 25nsec. Raising R8 to 31.6  $\Omega$  and lowering R3 to 301 $\Omega$  drops the variation to about 15nsec, and setting  $R8 = 59 \Omega$  with  $R3 = 274\Omega$  drops it to about 7nsec. The last case affects band-edge selectivity slightly ( $<0.5\text{dB}$ ), but does not change the filter's -3dB bandwidth. These group-delay variations are shown in Figure 3.

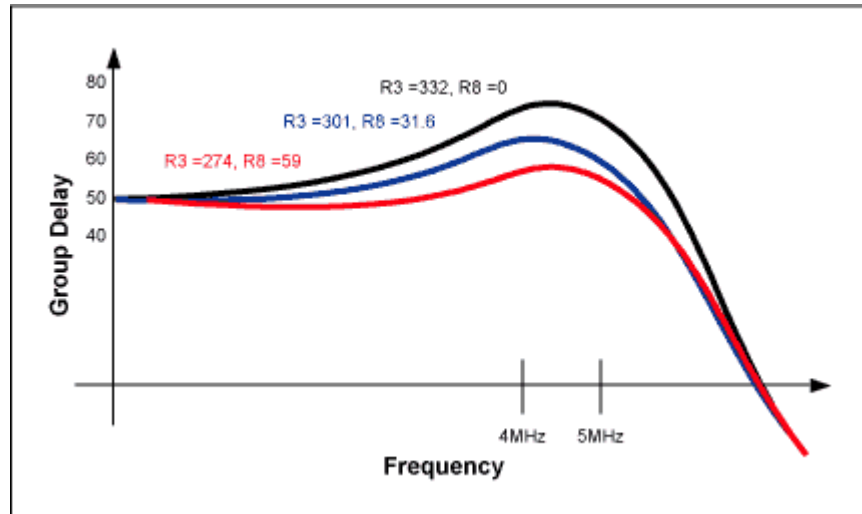

Figure 3. Selected values of  $R8$  and  $R3$  (see text) allow control of group-delay variation over the filter's passband.

A similar version of this article appeared in the August 8, 2002 issue of *EDN* magazine.

### MORE INFORMATION

MAX4390: [QuickView](#) -- [Full \(PDF\) Data Sheet \(520k\)](#) -- [Free Sample](#)